

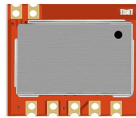

# 灵-T1mini 遥控模块



## 一、概述

灵-T1mini是一款二合一射频遥控模块,采用高性能RF SOC芯片,集成射频发射和百万组遥控编码,连接键即可成为遥控器,可过FCC/CE认证。

模块可搭配灵-R1mini 解码,组成射频遥控系统。灵-R1mini 输出 2 路开关量或者串口数据,有 5 种模式可选择: 翻转、点动、互锁、串口键值、PWM。整套系统免开发,视距可达 80 米左右,可快速量产。

灵-T1mini 适合各类家电、家居、物联网、玩具等遥控产品。

## 二、特点

- 电压范围 2.2V—3.6V (典型3V)
- 发射功率 10dBm@3V
- 发射电流 10 mA@3V
- 集成FB1527数字编码,自带百万组随机地址码
- 待机功耗低于1uA
- 支持4个按键



### 三、引脚

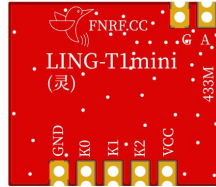

背面视图

序号	管脚名称	功能描述
1	VCC	电源正 (2.2~3.6V, 推荐3V)
2	K2	按键输入(内部上拉)、低电平发射
3	K1	K1+K2, K1+K0组合按键
4	K0	按键输入(内部上拉)、低电平发射
5	GND	电源地
6	G	电源地
7	A	天线 (50欧), 推荐TT02/TT05

接线图:

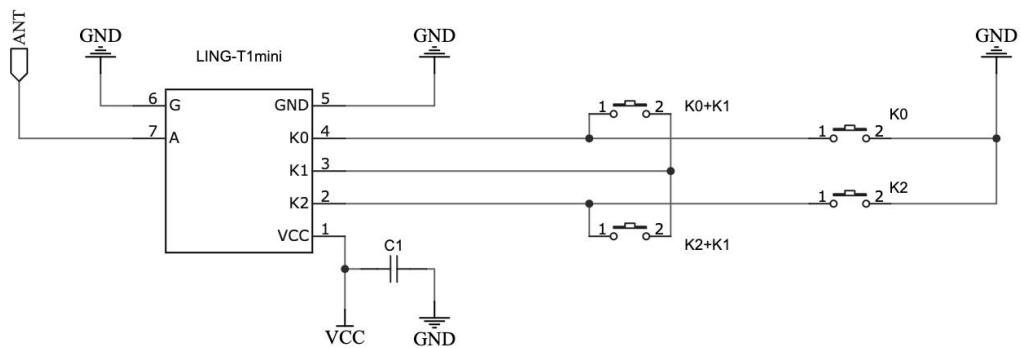



### 键值对应表

灵-T1mini	键值	灵-R1mini
K0	4	D0
K2	1	D1
K0+K1	8	串口模式下输出键值
K1+K2	2	串口模式下输出键值

需要4路输出请选用灵-R1、灵-R1pro

可通过开发助手查看键值:





#### 四、极限参数

Parameter	Symbol	Min	Max	Unit
Supply Voltage Range	VCC	-0.3	4	V
I/O Pin Voltage	VIO	-0.3	VCC+0.3V	V
Operating Temperature Range	TA	-20	70	°C
Storage Temperature Range	TSTG	-40	125	°C
ESD Rating	VESD		2	kV

#### 五、性能参数 (25°C)

Parameter	Symbol	Condition	Min	Typ	Max	Unit
Supply Voltage	VDD	-	2.2	3.0	3.6	V
Operating Current	ION	POUT=10 dBm	-	10		mA
Standby Current	IOFF	-	-	-	1	μA
Output Power	POUT	-	-	10	-	dBm
Transmission Rate	Rate	-	-	2	10	kbps



## 六、输出编码格式(FB1527码)

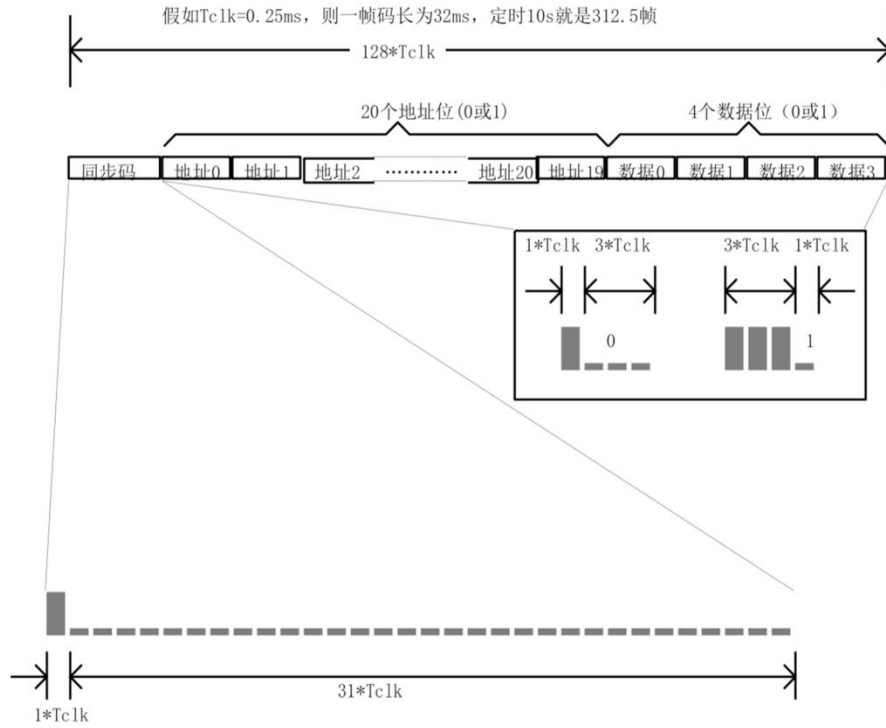

接收请用灵-R1系列接收模块, 输出2-4路开关量或通过串口输出键值。  
或者用远-R1L接收模块+MCU解码



## 七、用法

### 方案一



### 方案二



### 方案三





## 八、尺寸

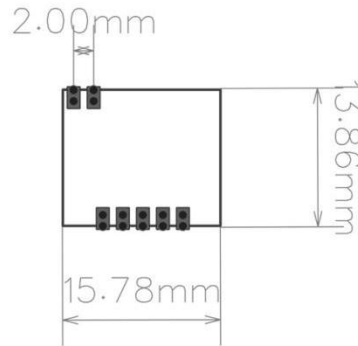

厚度(含屏蔽罩): 3.00mm

## 九、封装



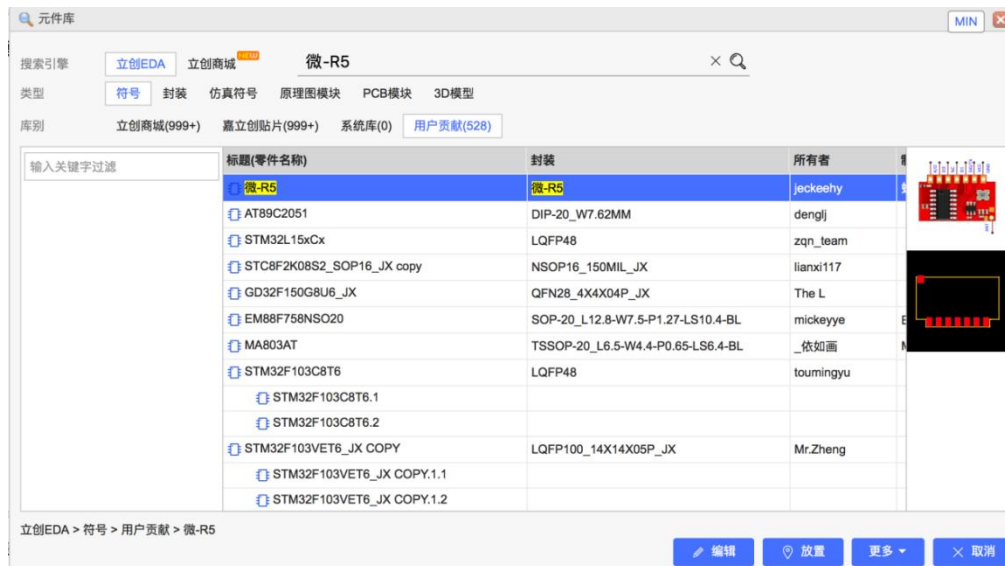

















推荐使用高效的国产 PCB 设计工具: 立创 EDA ([www.lceda.cn](http://www.lceda.cn)) 直接搜索“蜂鸟无线”或“产品型号”即可找到





## 十、天线

天线非常重要, 不接天线或天线不当会严重影响效果, 实际效果还和PCB、外壳、结构等有关, 建议多购买几种天线方便实测:

① 弹簧天线	 TT06	0.76元, 可选315/433/490MHz/2.5dBi/长27.5mm/带绝缘
	 TT05	0.36元, 可选433/315MHz/2.0dBi/长20.2mm/小尺寸 适用: 灵-T1mini/R1mini, 远-T1/R1
	 TT04	0.29元, 可选433/315MHz/2.5dBi/长19mm/低成本
	 TT02	0.99元, 可选433/315MHz/2.5dBi/长36mm/信号强 适用: 灵-T1mini/R1mini, 远-T1/R1/R6/T3/T3
	 TT24	0.39元, 2.4GHz/2dBi/长14mm 适用: 灵-TR5mini/TR7mini/TR3H
② 柔性天线	 TF41	1.68元, 433M/490M/17*37mm/6.0dBi/可选IPEX 1代座
	 TF45	1.68元, 433M/490M/17*45mm/6.0dBi/可选IPEX 1代座
	 TF49	1.98元, 490/510MHz/14*55mm/6.0dBi/可选IPEX 1代座 适用: 灵-TR6-490M
	 TF91	1.98元, 868M/915M/2.4GHz/20*70mm/6.0dBi/可选IPEX 1代座 适用: 灵-TR5mini/TR7mini/TR3H
	 TF58	1.58元, 2.4G、5.8G双频/WIFI、蓝牙专用天线/IPEX 4代座
③ 贴片天线	 FTP14P	0.88元, 433MHz/3.0dBi/长27mm
	 FTP14	0.43元, 433MHz/2.0dBi/长17mm/超小
	 TF43	1.68元, 433MHz/3.0dBi/长40mm/带3M胶/可选IPEX 1代座
	 TF21	1.68元, 2.4GHz/3.0dBi/长48mm/带3M胶/可选IPEX 1代座 适用: 灵-TR5mini/TR7mini/TR3H
④ 导线天线	TD01系列	0.2元, 可选315/433/490/915MHz/2.4GHz
⑤ 胶棒天线	 TJ系列	7.9元, 可选315/433/470/490MHz/6dBi/可折叠/长20cm
	 TJD系列	5.9元, 可选315/433/470/490MHz/3dBi/长5cm
	 TJ24	5.9元, 2.4GHz/2dBi/可折叠/长11cm
⑥ 吸盘天线	 TX41	8.9元, 433MHz/5dBi/高17cm
	 TX31	8.9元, 315MHz/5dBi/高16cm
	 TX49	8.9元, 470-510MHz/5dBi/高15cm



遥控数传, 蜂鸟更远!

---



扫码购天线



## 十一、开发工具

开发助手	信号助手
	
<p>不同点:</p> <ol style="list-style-type: none"> <li>1、测数据值</li> <li>2、有编码类型要求(1527 等)</li> </ol>	<p>不同点:</p> <ol style="list-style-type: none"> <li>1、测信号强度</li> <li>2、不限编码( ASK/OOK 调制 )</li> </ol>
<p>用途:</p> <ol style="list-style-type: none"> <li>1、显示遥控器/发射模块的地址码和按键值</li> <li>2、显示遥控频率、脉宽、编码类型</li> <li>3、遥控产品批量测试</li> </ol>	<p>用途:</p> <ol style="list-style-type: none"> <li>1、显示遥控器/发射模块信号强弱(相对值)</li> <li>2、对比天线好坏</li> <li>3、遥控产品批量测试</li> </ol>
<p>供电:</p> <p>TYPE-C</p>	<p>供电:</p> <p>TYPE-C</p>
 <p>微信扫码购买</p>	 <p>微信扫码购买</p>



## MINI 系列无线模块一览表

型号	灵-T1mini	灵-R1mini	灵-TR5mini	灵-TR7mini
图片				
价格	1.99 元	1.99 元	3.99 元	3.99 元
类型	发射	接收	收发	收发
视距	80 米	80 米	50 米	50 米
调制	ASK	ASK	FSK	FSK
频率	433.92MHz	433.92MHz	2483MHz	2483MHz
电压	2.2-3.6V (典型 3V)	2.0-5.5V (典型 3V)	2.2-3.6V (典型 3V)	2.2-3.6V (典型 3V)
工作电流	10mA	4.1mA	20mA@收 25mA@发	20mA@收 25mA@发
待机电流	<1uA	4.1mA	6uA	20mA (可定制 0.2mA/2mA)
亮点	4 键 低功耗 百万组编码 FCC/CE 认证	可对码 (30 组) 开关量/PWM 输出 串口键值输出 支持市面 RF 遥控器	串口透传 极低丢包率 频道可调 FCC/CE 认证	可对码 (32 组) 开关量输出 点动/翻转模式 FCC/CE 认证
应用	遥控灯/开关 无线呼叫器 物联网/安防产品	智能家居/家电遥控 厨卫产品遥控 物联网/安防产品	无线数据采集 智能家居控制 智能厨卫/家电遥控	智能家居遥控 汽车电子 安防报警器
推荐天线	TT06/TT04	TT06/TT04	TT24	TT24
编带包装				



遥控数传, 蜂鸟更远!

何杨

蜂鸟无线

13570812706

微信扫码技术咨询+获取开发资料

蜂鸟数传官方旗舰店

品质好物 今日特卖

RF遥控发射/4键/80米/FCC、CE认证

顺丰包邮 灵-T1mini遥控发射模块

RMB: 1.99

微信扫码购买